

# Z402



large character



Flexibility



Multi-control



Connectivity



Full integration

## Technical Specifications



large character

# Z402

## Printing characteristics

### PRINTING SPECIFICATIONS

- Up to two printing lines
- Print height from 5 mm to 60 mm (0,2" - 2,37")
- Coding throw distance up to 35 mm (1,37")
- Line speed capability: up to 180 m/min (591 ft/min)
- Printing rate: up to 266 ct/sec
- Available fonts: 5x4, 5x5, 6x4, 7x4, 7x5, 8x6, 9x5, 9x7, 10x8, 12x10, 16x10 e True Type
- Up to 6800 stroke per message
- Messages and logos storage: up to 4 GB with expandable Micro SD memory
- Automatic date, time, off sets and expiry date multifunctions
- Incrementing/decreasing alphanumeric product counters up to 9 digits
- Metric repeat print - message function
- Customizable message repeat with single print start
- Field orientation: 0°, 90°, 180°, 270°
- Tower print function (text rotation of 90°)
- Fixed and variable text field types (automatic or external)

### BARCODES

- 2/5 Industrial, UPC-A, CODE 39, EAN 13

## Construction characteristics

### CABINET

- 7" TFT full color anti-reflection high-contrast LED touch-screen display
- Stainless steel structure AISI 304
- Support on rubber feet or optional stainless steel structure AISI 304
- User interface and virtual keyboards with configurable foreign languages and alphabets
- Temperature: from 0°C to 50°C (32° F - 122° F)
- Humidity: 0-90% (non-condensing)
- Single phase, 85 - 240 Vac, 50 - 60 Hz, 175 VA

### EXTERNAL CONNECTIONS

- Serial connection RS232
- Ethernet interface for LAN 10/100 connection
- USB port version 2.0
- Parallel interface BCD, 6 bit
- Sensor management for product detection
- Shaft encoder input for variable speed production lines
- External alarm outputs for low ink level

## Usability

### PRINTER MANAGEMENT

- Real time throughput counter
- Management of one 16 or up to two 7 dot printheads
- Exclusive user interface customizable for single operator (functionality, language and alphabets...)
- Intuitive user interface with graphic icons
- Innovative graphic editor with Drag & Drop
- Quick creation of images, shapes and lines through touch-screen display
- Multi-level access with login
- Online help and user manual with contextual photos and videos
- Message storage with file name
- Print parameters storage in the messages
- Message dimension check before print

### PRINthead

- "Tilt" rotation bracket to obtain up to 5 different print heights
- Print heights 7 dot head: 7, 10, 12, 16 and 20 mm
- Print heights 16 dot head: 16, 30, 40, 50 and 60 mm
- Stainless steel structure AISI 304
- High efficiency solenoid technology
- Printhead - console distance: up to 10 m (33 ft)
- Stainless steel nozzle plate AISI 304
- Purge and calibration per single dot

## Consumables

### INKS

- Wide range of inks to satisfy any application and surface, all compliant with RoHS: water-based, ketone-based (MEK) and alcohol-based (methanol-free) inks
- Food Contact certified inks for food packaging

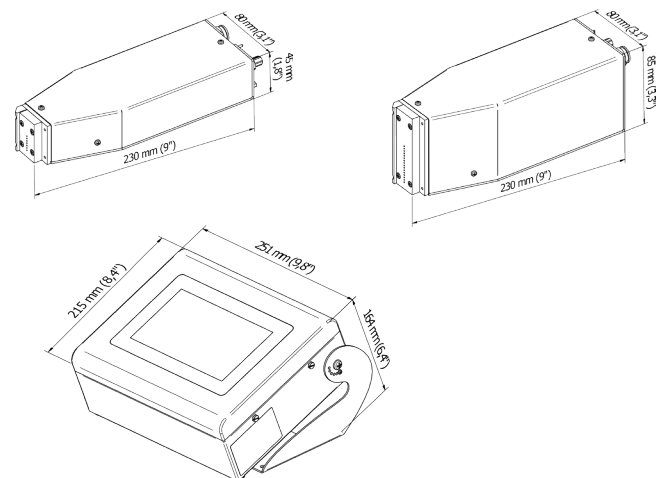

 **ZANASI**  
make your mark

ZANASI SRL Via Marche n.10  
41049 Sassuolo (MO)  
Tel. +39 0536 99.97.11



zanasicoding.com